



ENGINE

Make	: Mercedes-Benz 6R1100
Type	: High power and torque output, water cooled, turbocharged diesel engine.
Number of Cylinders	: 6 in line
Bore & Stroke	: 125 x 145 mm
Displacement	: 10.700 cc
Maximum Power	: 324 HP (242 kW) @1800 rpm
Maximum Torque	: 1600 Nm @1300 rpm
Conforms to European Stage IV exhaust gas emission regulations	

TRANSMISSION

- Autoshift transmission for heavy duty service
- 5 forward, 3 reverse gears
- Torque converter with 2.194:1 stall ratio
- 4 Wheel Drive
- Transmission oil cooler
- Engine start only at the gear lever on neutral position for safety.
- Electronic parking brake

HYDRAULIC SYSTEM

Closed center type hydraulic system with LS type variable displacement piston type pumps.

Pump Flow (Pump 1)	: 190 L/min @1900 rpm
Pressure (Pump 1)	: 250 bar
Pump Flow (Pump 2)	: 190 L/min @1900 rpm
Pressure (Pump 2)	: 210 bar
Pump Flow (Pump 3)	: 85 L/min @1900 rpm
Pressure (Pump 3)	: 250 bar

DRIVING SPEED

@1900 rpm engine speed

1 st gear	: 6,8 km/h
2 nd gear	: 11,7 km/h
3 rd gear	: 18,3 km/h
4 th gear	: 25,4 km/h
5 th gear	: 37,8 km/h

AXLES

- Heavy duty type ZF axles
- Planetary type reduction gears
- Total 26 degrees oscillation on the rear axle
- Equipped with differential lock on the front axle

CAB & HOOD

- Widened visual angle
- Ergonomic & Aesthetic Interior Design
- 8" LCD coloured touchpad display
- Improved Opera Control System
- Externally servicable Air Conditioner system
- Cool-box
- Electro hydraulic control levers
- ROPS and FOPS certificated cab
- 35° tilting cab for maintenance
- Air suspension seat with heating
- TIPSHIFT control on operator console
- Pool type floor mats
- Tablet PC and phone holder
- SmartLink (Optional)
- Storage boxes for operator
- Sun-wisors
- LED headlamps
- LED working lighths
- Electrically controlled side mirrors with heating
- Rear view camera
- One-piece opening hood, electrically controlled.
- Independently adjustable joystick console and armed

TIRES

Front / Rear : 26,5R25-L3

OPERATING WEIGHT

Operating weight (with standard equipment) : 26.300 kg

Operational weight, complying with the ISO 6016 standards, includes full fuel tank, hydraulic system and other liquids, 75 kg operator weight and standard equipped machine weight. Optional equipments are not included.

HMK 640 WL

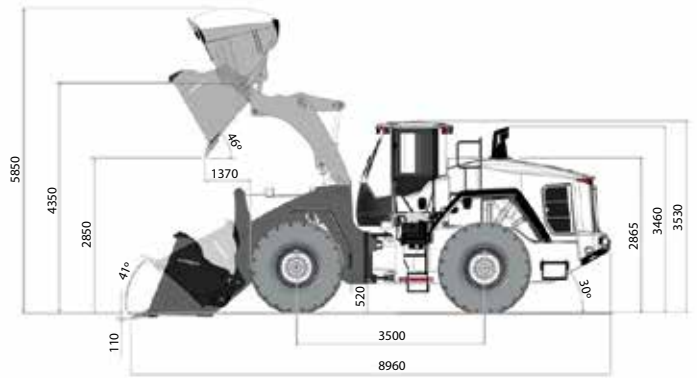
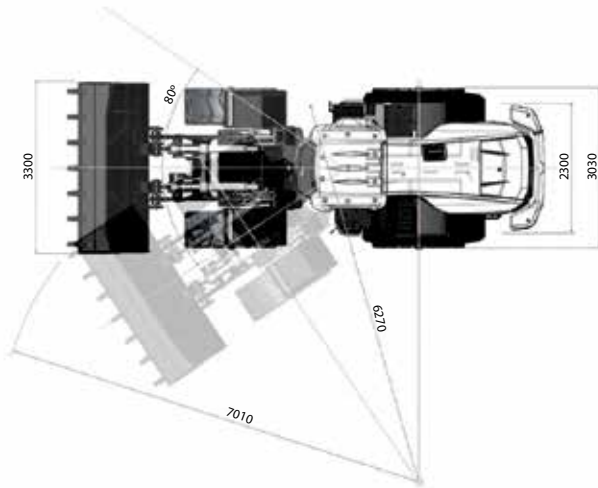

PERFORMANCE

Bucket capacity	4,2 m ³
Max. breakout force	19.975 kgf
Static tipping load (no tire deflection)	19.269 kgf
Static tipping load- articulated (no tire deflection)	17.015 kgf

FILLING CAPACITIES

Cooling system	: 50 L
Fuel tank	: 400 L
Total engine oil	: 35 L
Transmission oil (replacement)	: 32 L
Total transmission oil required (system)	: 50 L
Rear axle	: 42 L
Front axle	: 61 L
Hydraulic oil (replacement)	: 135 L
Total hydraulic oil required (system)	: 200 L
Diesel Engine Fluid (Adblue®)	: 40 L

LINKAGE

- Double Z-bar
- Auto-lift
- Return to Dig (RTD)
- Auto bucket Kick-out

HYDRAULICS

- Load sensing steering and hydraulics
- Ride Control System (MSS)
- Proportional and bi-directional hydrostatic fan
- Emergency steering system
- Easy access to pressure measurement points

ELECTRICAL AND LIGHTING

- 24 V
- Batteries 2 x 12 V, 1200 CCA
- Alternator, 100 A
- LED headlamps
- LED working lamps (4 front, 4 rear, 2 hood)
- LED stoplights
- Ignition key, start stop switch
- 12 V outlet
- Reverse Alarm
- Main disconnect switch

HIDROMEK®

FACTORY - HEAD OFFICE
 Ahi Evran OSB Mahallesi Osmanlı Caddesi No:1 06935 Sincan / ANKARA / TURKEY
 Tel: (+90) 312 267 12 60 Fax: (+90) 312 267 12 39
 www.hidromek.com

Notice:
 Hidromek has the right to modify the specifications and design of the model indicated on this brochure without prior notice.