



ENGINE

Model	: ISUZU AR-4J1XASW-2
Type	: Water cooled, 4 cycle, 4 cylinders, line type direct injection, turbocharger, electronic diesel engine
Power	: 105 HP (78,5 kW) @2000 rpm / SAE J1995 (Gross) : 102 HP (76,4 kW) @2000 rpm / SAE J1349 (Net)
Max. Torque	: 375 Nm @1800 rpm (Gross) : 362 Nm @1800 rpm (Net)
Displacement	: 2999 cc
Bore and Stroke	: 95,4 mm x 104,9 mm
This engine complies with the Emission Regulations U.S. EPA Tier 4 Final, and EU Stage 4	

UNDERCARRIAGE

Shoe	: Triple grouser 500 mm
No. Of Shoes	: 2 x 46
No. Of Lower Rollers	: 2 x 7
No. Of Upper Rollers	: 2 x 2
Track Tensioning	: Hydraulic Spring Tensioning

CAB

- Wide cab and easy entrance
- Use of six viscomount cabin mountings that dampen the vibrations
- Cooled storage room
- Colourful, Easy to read TFT indicant monitor
- Glass holder, book and object storage pockets
- Full automatic digitally air-conditioner
- Overclass standarts on the visibility
- Pool type flor mat
- Improved operator's comfort through versatile adjustable seat
- Ergonomically redesigned cabin through relocated switch board, and re-styled travel pedals and levers
- USB connected MP3 player
- Easy to open the front sliding glass
- Front and rear sun visor
- Large storage areas
- Height adjustable joystick
- Improved seat to back angle
- The height adjustable seat armrests
- Opera Control System

TRAVEL AND BRAKERS

Travel	: Fully hydrostatic
Travel Motors	: Axial piston type
Reduction	: 2 stage planetary gear
Travel Speed	
High Speed	: 5,7 km/h
Low Speed	: 3,4 km/h
Max. Drawbar Pull	: 11.230 kgf
Gradeability	: 35° (%70)
Parking Brake	: Hydraulic multi disc type
Ground Pressure (500mm Shoe):	0,51 kgf/cm ²

LUBRICATION

Centralized lubrication system is provided for lubrication all difficult-to-reach parts on the components, such as boom and arm

HYDRAULIC SYSTEM

Main Pump	
Type	: Double variable displacement axial piston pumps
Max. Flow	: 2 x 124 L/min (62 cc/rev)
Pilot Pump	: Gear, 20 L/min (10 cc/rev)
Relief Valves	
Attachment	: 320 kgf/cm ²
Power Boost	: 350 kgf/cm ²
Travel	: 350 kgf/cm ²
Swing	: 260 kgf/cm ²
Pilot	: 40 kgf/cm ²
Cylinders	
Boom 1	: 2 x ø110 x ø 75 x 1030 mm
Boom 2	: 1 x ø150 x ø 90 x 750 mm
Arm	: 1 x ø115 x ø 80 x 1225 mm
Bucket	: 1 x ø100 x ø 70 x 910 mm
Dozer	: 2 x ø100 x ø 70 x 240 mm

OPERA CONTROL SYSTEM

- Easy-to-use control panel and menus
- Overheat prevention and protection system without interrupting the work
- Automatical electric power-off
- Maximum efficiency by selection of power and work modes
- Error mode registry and warning system
- Improved fuel economy and productivity
- Automatic idling Selection of multi-language on control panel
- Rear-view, arm-view camera (Optional)
- Possibility to register 26 different operating hours
- Anti-theft system with personal code
- Real time monitoring of operational parameters such as pressure, temperature, engine load

SWING SYSTEM

Swing Motor	: Axial piston type integrated with shock absorber valves
Reduction	: 2 stage planetary gear box.
Swing Brakes	: Hydraulic multi disc type, automatic warnings
Swing Speed	: 11,4 rpm

CAPACITY

Fuel Tank	: 240 L	Engine Oil	: 8 L
Hydraulic Tank	: 165 L	Swing Reduction	: 3 L
Radiator	: 25 L	Travel Reduction	: 2,1 x 2 L
Hydraulic System	: 210 L	Urea tank	: 35 L

ELECTRICAL SYSTEM

Voltage	: 24V
Battery	: 2 x 12 V x 100 Ah
Alternator	: 24V / 50 A
Starting Motor	: 24V / 4 kW

OPERATING WEIGHT

Standard machine operating weight : 16.800 kg

Operational weight, complying with the ISO 6016 standards, includes full fuel tank, hydraulic system and other liquids, 75 kg operator weight and standard equipped machine weight. Optional equipments are not included.

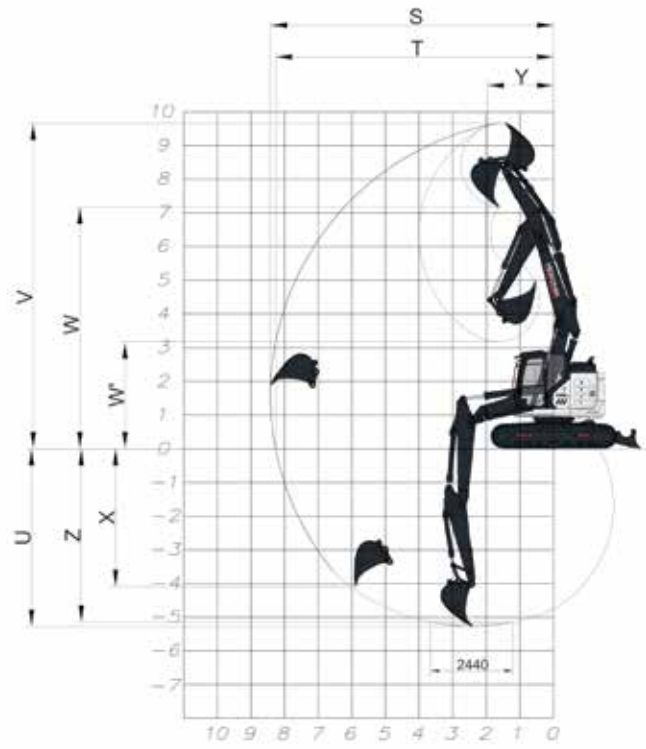
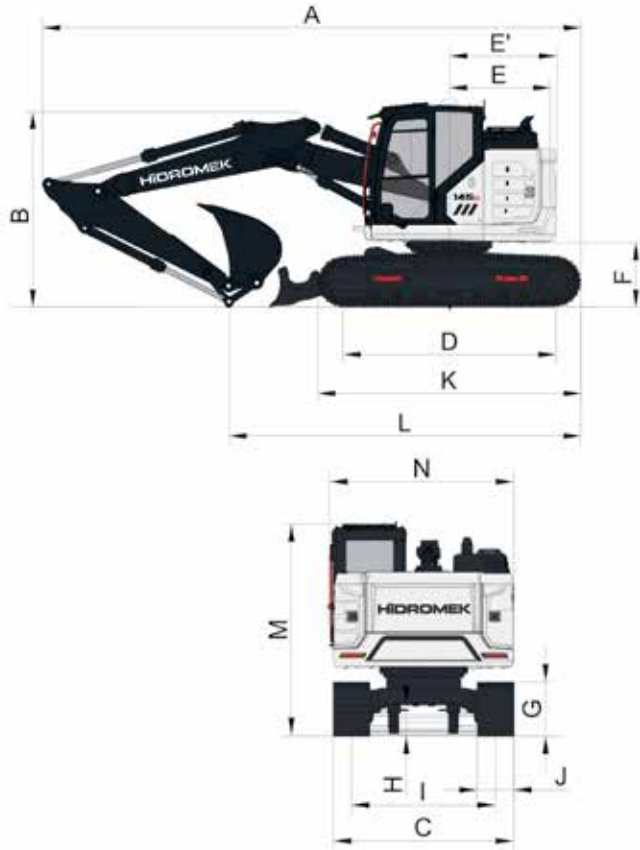

GENERALE DIMENSIONS

Boom dimension	4800 mm			
Arm dimension	2000 mm	*2300 mm	2600 mm	2900 mm
A - Overall length	7710 mm	7710 mm	7680 mm	7650 mm
B - Overall height (to top of boom)	2700 mm	2810 mm	2940 mm	3030 mm
C - Overall width (of lower structure)	2510 mm			
D - Idler distance	3035 mm			
E - Tall swing radius	1500 mm			
E' - Tall swing distance	1520 mm			
F - Upperstructure ground clearance	940 mm			
G - Crawler height	800 mm			
H - Min. Ground clearance	430 mm			
I - Track gauge	1990 mm			
J - Shoe width	*500 / 600 / 700 mm			
K - Overall length of crawler	3780 mm			
L - Length over ground	5190 mm	5040 mm	4910 mm	4710 mm
M - Overall height (to top of cab)	2960 mm			
N - Upperstructure width	2500 mm			

* Standard

WORKING DIMENSIONS

Boom dimension	4800 mm			
Arm dimension	2000 mm	*2300 mm	2600 mm	2900 mm
S - Max. digging reach	8250 mm	8530 mm	8840 mm	9130 mm
T - Max. digging reach at ground level	8090 mm	8380 mm	8690 mm	8990 mm
U - Max. digging depth	5080 mm	5380 mm	5690 mm	5980 mm
V - Max. digging height	9510 mm	9780 mm	10070 mm	10340 mm
W - Max. dumping height	6790 mm	7060 mm	7350 mm	7620 mm
W' - Min. dumping height	3310 mm	3060 mm	2810 mm	2510 mm
X - Max. vertical digging depth	4460 mm	4780 mm	5120 mm	5410 mm
Y - Min. swing radius	1830 mm	1990 mm	2160 mm	2250 mm
Z - Max. digging depth (2440mm level)	4960 mm	5260 mm	5570 mm	5870 mm

DIGGING PERFORMANCE

Standard Bucket Capacity (SAE)	0,6 m ³			
Bucket Digging Force (Power Boost) ISO	9100 (10000) kgf			
Arm Crowd Force (Power Boost) ISO	7500 (8200) kgf	6800 (7500) kgf	6200 (6800) kgf	5700 (6300) kgf

HIDROMEK®

FACTORY - HEAD OFFICE

Ahi Evran OSB Mahallesi Osmanlı Caddesi No:1 06935 Sincan / ANKARA / TURKEY
 Tel: (+90) 312 267 12 60 Fax: (+90) 312 267 12 39
www.hidromek.com

Notice:
 Hidromek has the right to modify the specifications and design of the model indicated on this brochure without prior notice.